

Triple Eccentric Butterfly Valves Metal Seal, Lug

600PSI / Class300

Design to ASME B16.34/API609

Dimensions to ASME B16.5/B16.1/EN1092

Pressure Test to API598/ISO5208

Temperature Range: -50°C~650°C/-58°F~1200°F



HP5203-2

Materials List		
1	Lower End Cap	ASTM A105
2	Lower Shaft Sleeve	ASTM A276 304
3	Body	ASTM A216 WCB ASTM A351 CF8/CF8M
4	Lower Stem	ASTM A276 431 ASTM A564 630-17-4PH
5	Cylindrical Pin	ASTM A182 F304
6	Disc	ASTM A216 WCB ASTM A351 CF8/CF8M
7	Upper Stem	ASTM A276 431 ASTM A564 630-17-4PH
8	Upper Shaft Sleeve	ASTM A276 304
9	Packing	Graphite
10	Packing Gland	ASTM A216 WCB
11	Support	Carbon Steel
12	Seat	SS316, Stellite, Inconel
13	Seal Ring	SS316 + Graphite
14	Press Plate	ASTM A105 ASTM A182 F316
15	Hexagon Socket Head Bolt	ASTM A193 B7
16	Support Bolt	ASTM A193 B7
17	Spring Washer	ASTM A29 1566
18	Nut	ASTM A194 2H
19	Gland Bolt	ASTM A193 B7
20	Spring Washer	ASTM A29 1566
21	Nut	ASTM A194 2H

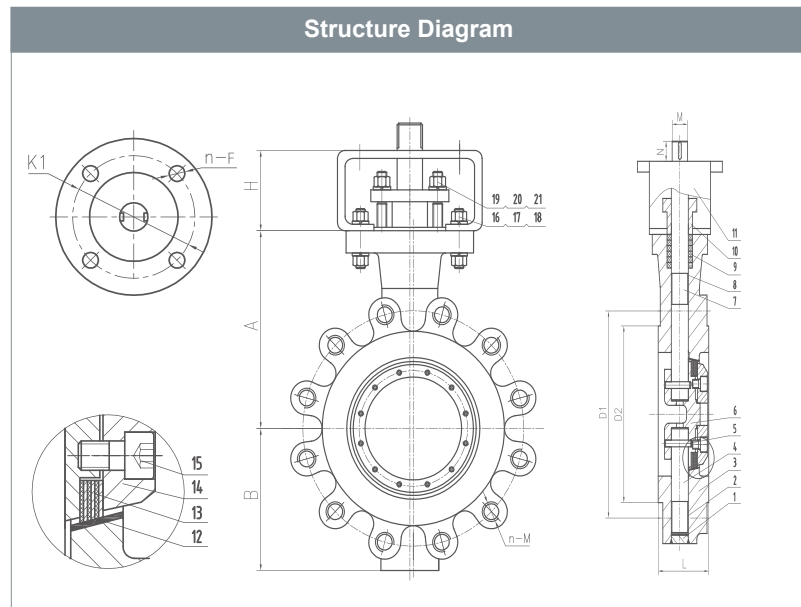

* For other materials and special requirements, consult factory or local offices.

Dimensions(300LB)											
In	L	D1	D2	n-M	H	A	B	M	N	K1	n-F
3	48	168.3	127	4-M20	65	160	105	18	35	70	4-10
4	54	200	157.2	8-M20	65	170	115	22	40	70	4-10
5	56	235	185.7	8-M20	65	190	130	24	45	102	4-12
6	59	269.9	215.9	12-M20	65	210	155	28	50	102	4-12
8	73	330.2	269.9	12-M24	90	240	190	35	50	125	4-14
10	83	387.4	323.8	16-M27	90	280	230	38	55	125	4-14
12	92	450.8	381	16-M30	120	310	250	42	55	140	4-18
14	117	514.4	412.8	20-M30	120	360	300	52	60	165	4-22
16	133	571.5	469.9	20-M33	120	410	370	58	70	165	4-22
18	149	628.6	533.4	24-M33	150	440	400	68	80	200	8-18
20	159	685.8	584.2	24-M33	150	460	420	76	80	254	8-18
24	181	812.8	692.2	24-M39	170	500	460	82	100	298	8-22

* For EN and other standards dimensions, consult factory.